

December 2016

Version 2.3

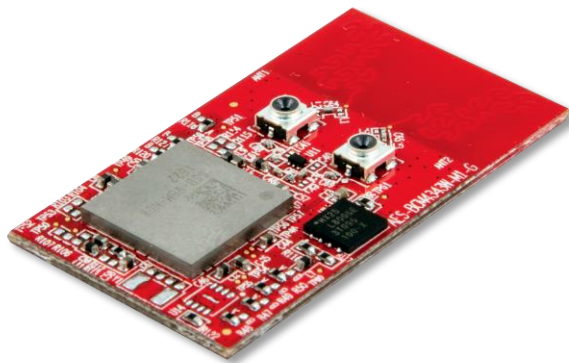

Description

The Avnet AES-BCM4343W-M1-G module is a high performance, Wi-Fi and Bluetooth/BLE combo module that includes a programmable ARM® Cortex™ M4 microprocessor for running user application code. The module is ideal for low-power Internet of Things (IoT) enabled sensor and actuator based devices that need wireless connectivity to cloud services. The compact 35 x 20mm LGA package makes the module a perfect fit for small, embedded applications.

This Avnet SoC Module is pre-certified, thus minimizing development time and certification costs. The module combines an advanced Cypress® 2.4GHz 802.11 b/g/n and Bluetooth® 4.1 SoC with 8Mb of serial Flash and a ST Microelectronics STM32F411 ARM® Cortex™ M4 MCU supporting 512KB Flash and 128KB SRAM. Several of the M4 MCU peripheral functions are made available on the module I/O, allowing for easy connection to user specified interfaces. Advanced security capabilities are available with an optional authentication chip.

Dual onboard fractal PCB antennas provide antenna diversity for optimized RF performance.

Applications

- Industrial Automation
- Security & Building Automation
- Smart Home Appliances
- IoT and M2M Connectivity
- Wi-Fi/BLE Gateway

Features

- Based on integrated SIP device that includes:
 - Combo Wi-Fi & BT/BLE SoC (BCM4343W)
 - Host Application Processor (STM32F411)
- BCM4343W WLAN radio:
 - 2.4 GHz IEEE 802.11b/g/n(20), Channels 1-11 for USA and Canada
- BCM4343W Bluetooth radio:
 - Bluetooth® v4.1 (LE and Classic modes)
- STM32F411 ARM® Cortex™ M4 microcontroller features include:
 - 512KB Flash and 128KB SRAM
 - Multiple peripheral interfaces:
 - Digital I/O – 6
 - Analog inputs – 4
 - I2C Ports – 2
 - SPI Port – 1
 - UART Ports - 2
 - JTAG programing and debug port
- 8Mb SPI serial flash for storage of firmware upgrades and user accessible R/W file system
- Antenna Diversity implemented using onboard dual fractal PCB antennas
- Concurrent WLAN and Bluetooth operation (coexistence algorithm for shared antennas)
- Comprehensive software development tools:
 - Cypress WICED™ SDK
 - ZentriOS SDK
- Compact 35 x 20 mm 45-pin LGA package
- Operating temperature: -40° to +85° C
- FCC, IC and CE certifications: currently pending
- BT SIG QDID: coming soon

Document Control

Document Version:	Version 2.3		
Document Date:	29 December 2016		
Document Author(s):	JB, PF		
Document Classification:	Released		
Document Distribution:	Public		
Prior Version History:	Version:	Date:	Comment:
	0.1	5/2/16	Initial release
	0.2	5/2/16	Updated Module Features
	0.3	5/2/16	Added SPI flash and Antenna details
	1.0	6/27/16	Tape & Reel Packaging and Antenna Options sections updated
	2.0	11/16/16	Specs for low-power modes added References to Broadcom removed Reference to BT/BLE 4.2 removed Option of using external antennas removed
	2.1	12/19/16	Miscellaneous updates. Wi-Fi and BT versions and channel detail added
	2.2	12/23/16	256-QAM (TurboQAM) mode removed Data rate max reduced to 65 Mbps Regional contact info updated
	2.3	12/29/16	Regulatory compliance statements and OEM labeling requirements updated. Avnet Legal statement added

Comments:

1 Table of Contents

2	Table of Figures	5
3	Functional Overview.....	6
3.1	Microcontroller.....	6
3.2	SPI Flash Memory.....	6
3.3	WLAN	7
3.4	Bluetooth.....	7
3.5	Antennas.....	7
4	Block Diagram.....	8
5	Module Pin Descriptions	9
5.1	Pin Descriptions	9
5.2	Pin Definitions	10
6	Electrical Specifications	11
6.1	Absolute Maximum Ratings.....	11
6.2	Recommended Operating Conditions.....	11
6.3	Power Supply Requirements	11
6.4	WLAN Power Consumption.....	12
6.5	Bluetooth Power Consumption	12
6.6	Bluetooth Low Energy Power Consumption	12
6.7	Low Power Modes Power Consumption	12
7	RF Specifications	13
7.1	WLAN RF Characteristics.....	13
7.1.1	Transmitter Specification	14
7.1.2	Receiver Specification	15
7.2	Bluetooth RF Characteristics.....	17
7.2.1	Transmitter Specification	17
7.2.2	Receiver Specification	17
7.3	BLE RF Characteristics	18
8	Mechanical Specifications.....	19
8.1	Mechanical Size	19
8.2	Module PCB Footprint	20
8.3	Module Pad Size	20
8.4	Recommended Solder Paste Mask	21
8.5	Recommended Solder Mask	21
8.6	Tape and Reel Packaging	22
9	Soldering and Cleaning Recommendations	23
9.1	Optimum Soldering Reflow Profile.....	23



9.2	Cleaning.....	23
10	Antennas.....	24
11	Certifications	25
11.1	RoHS	25
11.2	Regulatory Compliance	25
11.3	Bluetooth Interoperability Compliance	25
11.4	Regulatory Agency Statements	25
11.4.1	FCC Module Statement (USA)	25
11.4.2	FCC Interference Statement (USA).....	26
11.4.3	FCC RF Exposure Statement (USA).....	26
11.4.4	FCC Cautionary Notices (USA).....	26
11.4.5	FCC Host 15B and 15C Compliance Statement (USA)	27
11.4.6	IC Statement (Canada).....	27
11.4.7	IC Labeling Requirements (Canada).....	27
11.4.8	CE Statement (Europe)	28
11.4.9	CE Labeling Requirements (Europe).....	28
11.5	OEM Instructions.....	28
11.6	OEM Labeling Requirements	28
11.7	Limitations.....	28
12	Shipping, Handling and Storage	29
12.1	Shipping.....	29
12.2	Handling.....	29
12.3	Moisture Sensitivity (MSL).....	29
12.4	Storage	29
13	Ordering Information	30
13.1	Module Accessories	30
14	Contact Information.....	31



2 Table of Figures

Figure 1 – AES-BCM4343W-M1-G Module Block Diagram.....	8
Figure 2 – AES-BCM4343W-M1-G Module Top View	19
Figure 3 – AES-BCM4343W-M1-G Module Side View	19
Figure 4 – AES-BCM4343W-M1-G Module PCB Footprint.....	20
Figure 5 – AES-BCM4343W-M1-G Module Pad Size.....	20
Figure 6 – Recommended Solder Paste Mask Size	21
Figure 7 – Recommended Solder Mask Size.....	21
Figure 8 – Tape Dimensions	22
Figure 9 – Recommended Soldering Profile for Lead-Free Solder	23
Figure 10 – Dual Fractal PCB Antennas	24
Figure 11 – Test Probe Connectors (Murata SWD series)	24



3 Functional Overview

This 2.4GHz wireless module provides a complete combo Wi-Fi/BT/BLE and MCU solution for cost-effective embedded-wireless IoT applications. Based on latest-generation Cypress BCM4343W Wireless SoC silicon, this high performance combo module provides a unique solution with Wi-Fi and Bluetooth radios, ARM Cortex-M4 host processor and expansion SPI Flash memory, plus versatile dual onboard and dual external antenna capabilities, all in a compact 35 mm x 20 mm, easy to mount (0.1" pitch LGA) form-factor module, qualified for operation across the full industrial temperature range

3.1 Microcontroller

The AES-BCM4343W-M1-G module includes an on-board microcontroller (MCU) that interfaces with the Cypress BCM4343W radio for communication and acts as the system controller for user applications. Based on the ST Microelectronics STM32F411, the MCU supports the following features:

- STM32F411 ARM 32-bit Cortex™-M4 (with FPU), @ 100 MHz
- On-chip memory: 512 kbytes Flash, 128 Kbytes SRAM
- Multiple serial communication interfaces: SPI, USART, PCM
- Sensor applications support: ADC, I2C, I2S, GPIO, Timers
- Cypress WICED SDK and ZentriOS SDK based cloud connected application examples are provided (AWS IoT, IBM Bluemix, ThingSpeak and others...)
- Debug support: JTAG interface

Application code for the module can be developed using Cypress's WICED Software Development Kit (SDK) or Zentri's ZentriOS SDK.

Additional details on the STM32F411 MCU features, specifications, and programming modes can be obtained from the STM32F411 datasheet.

3.2 SPI Flash Memory

An 8 Mbit SPI Flash memory (Macronix MX25L800EZUI12G) is included on the module for the storage of BCM4343W firmware, static webpages, built-in documentation, images, etc. The STM32F411 MCU's SPI1 peripheral interface, clocked at 50MHz, is used to communicate with this memory.

The SPI1 interface parameters are defined in the **BCM94343W_AVN** platform files of the Cypress WICED SDK development environment. When building an application in WICED SDK, adding the **download_apps** parameter to the make target command string, ensures that the BCM4343W firmware is written to- and loaded from this SPI flash

	MCU	WICED SDK
SPI1 Signal Name	Pin Name	Pin Name
SPI_FLASH_CS	PA4	WICED_GPIO_5
SPI_FLASH_CLK	PA5	WICED_GPIO_6
SPI_FLASH_MISO	PA6	WICED_GPIO_7
SPI_FLASH_MOSI	PA7	WICED_GPIO_8

3.3 WLAN

- Cypress BCM4343W combo single-chip MAC, Baseband and RF device (includes ARM Cortex-M3 processor)
- Frequency Band: Single-band, 2.4 GHz only
- WLAN Network Standards supported: 802.11b, 802.11g, 802.11n (single stream)
- Modulation Modes: CCK and OFDM with BPSK, QPSK, 16QAM, 64QAM
- Supported Data Rates:
 - IEEE 802.11b 1 – 11 Mbps
 - IEEE 802.11g 6 – 54 Mbps
 - IEEE 802.11n 7.2 – 65 Mbps (2.4 GHz only)
- Hardware Encryption
 - WEP, WPA / WPA2 Personal
- Advanced 1x1 802.11n Features:
 - Full/Half Guard Interval
 - Frame Aggregation
 - Space Time Block Coding (STBC)
 - Low Density Parity Check (LDPC) Encoding
- SDIO host interface for WLAN subsystem (between BCM4343W and STM32F411 MCU)
- Optional WLAN Debug Interfaces:
 - WLAN JTAG and WLAN Debug UART interfaces are pinned-out to support special cases (most application development will not require this)

3.4 Bluetooth

- Bluetooth 4.1 (supporting Bluetooth Low Energy) with backward compatibility
- Bluetooth Smart Ready (support for Dual-mode Bluetooth Classic and BLE operation)
- Advanced Algorithm for support of Bluetooth/BLE and Wi-Fi coexistence (for concurrent WLAN and Bluetooth operation)
- Dedicated high-speed UART for Bluetooth host interface

3.5 Antennas

- Onboard dual fractal PCB antennas (Cypress patented PCB trace antennas)
- Miniature switched RF connectors. These are for test purposes only!
- Transmit and Receive antenna diversity

4 Block Diagram

Figure 1 shows a functional block diagram of the AES-BCM4343W-M1-G module.

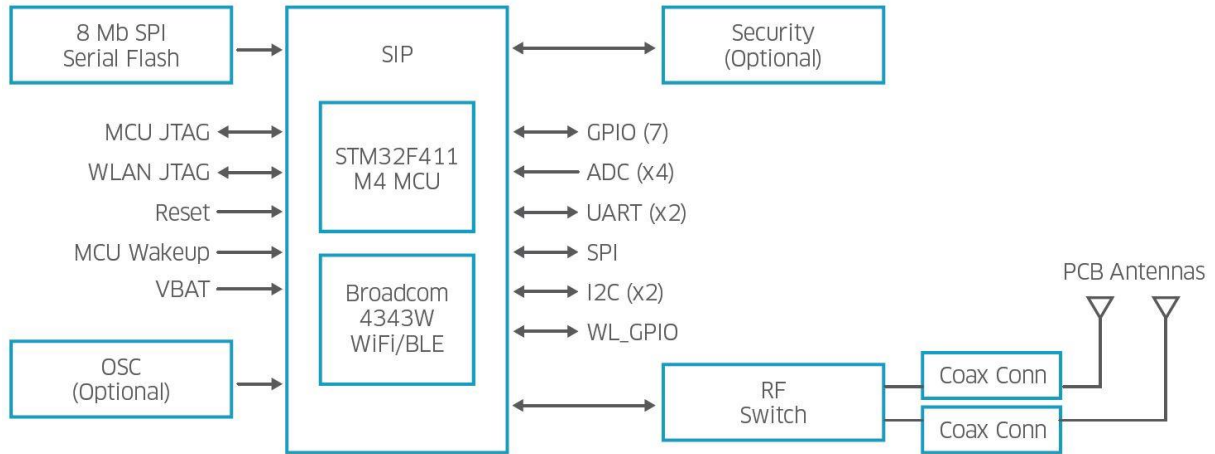

Figure 1 – AES-BCM4343W-M1-G Module Block Diagram

5 Module Pin Descriptions

5.1 Pin Descriptions

Module			MCU	WICED SDK	
Pin No.	Signal Name	Type	Pin Name	Pin Name	Description*
1	GND	SIG	-	-	Ground
2	MICRO_I2C2_SCL	I/O	PB10	WICED_GPIO_20	I2C #2 SCL
3	MICRO_I2C2_SDA	I/O	PB11	WICED_GPIO_21	I2C #2 SDA
4	MICRO_SPI2_SCK	I/O	PB13	WICED_GPIO_23	SPI #2 SCK
5	MICRO_SPI2_SSN	I/O	PB12	WICED_GPIO_22	SPI #2 SSN
6	MICRO_SPI2_MISO	I/O	PB14	WICED_GPIO_24	SPI #2 MISO
7	MICRO_SPI2_MOSI	I/O	PB15	WICED_GPIO_25	SPI #2 MOSI
8	USART6_TX_I2S2_MCK	I/O	PC6	WICED_GPIO_13	USART #6 TX
9	USART6_RX_I2S2_CK	I/O	PC7	WICED_GPIO_14	USART #6 RX
10	MICRO_UART_TX	I/O	PA9	WICED_GPIO_9	USART #1 TX
11	MICRO_UART_RX	I/O	PA10	WICED_GPIO_10	USART #1 RX
12	MICRO_UART_CTS	I/O	PA11	WICED_GPIO_15	USART #1 CTS
13	MICRO_UART_RTS	I/O	PA12	WICED_GPIO_16	USART #1 RTS
14	WIFI_GPIO_1	I/O	PD13	-	WLAN Tx/Rx Activity (Driven by GPIO_1 of BCM4343W device)
15	GND	SIG	-	-	Ground
16	VDD_3V3_SIP	SIG	-	-	3.3V
17	GND	SIG	-	-	Ground
18	WL_JTAG_TDI	N/C	-	-	No Connect (requires hardware modification for connection)
19	WL_JTAG_TDO	N/C	-	-	No Connect (requires hardware modification for connection)
20	MICRO_JTAG_TMS	I/O	PA13	-	JTAG TMS
21	MICRO_JTAG_TCK	I/O	PA14	-	JTAG TCK
22	MICRO_JTAG_TDI	I/O	PA15	-	JTAG TDI
23	MICRO_JTAG_TDO	I/O	PB3	-	JTAG TDO
24	MICRO_JTAG_TRSTN	I/O	PB4	-	JTAG RESETN
25	GND	SIG	-	-	Ground
26	VBAT_SIP	SIG	-	-	Power supply for backup when VDD_3V3_SIP is not present
27	GND	SIG	-	-	Ground
28	MICRO_I2C1_SCL	I/O	PB6	WICED_GPIO_11	I2C #1 SCL
29	MICRO_I2C1_SDA	I/O	PB7	WICED_GPIO_12	I2C #1 SDA
30	MICRO_GPIO_3	I/O	PC1	WICED_GPIO_27	GPIO 3
31	MICRO_GPIO_2	I/O	PC0	WICED_GPIO_26	GPIO 2
32	MICRO_GPIO_4	I/O	PC2	WICED_GPIO_28	GPIO 4
33	MICRO_GPIO_5	I/O	PC3	WICED_GPIO_17	GPIO 5
34	MICRO_GPIO_6	I/O	PB9	WICED_GPIO_19	GPIO 6
35	MICRO_GPIO_1	I/O	PB8	WICED_GPIO_18	GPIO 1
36	MICRO_RST_N	I/O	NRST	-	RESET_N
37	MICRO_ADC_IN1	I/O	PA1	WICED_GPIO_2	ADC INPUT #1
38	MICRO_WKUP	I/O	PA0	WICED_GPIO_1	MCU WAKEUP
39	GND	SIG	-	-	Ground
40	MICRO_ADC_IN2	I/O	PA2	WICED_GPIO_3	ADC INPUT #2
41	MICRO_ADC_IN3	I/O	PA3	WICED_GPIO_4	ADC INPUT #3
42	MICRO_GPIO_0	I/O	PB0	WICED_GPIO_29	GPIO 0
43	MICRO_ADC_IN15	I/O	PC5	WICED_GPIO_30	ADC INPUT #15
44	GND	SIG	-	-	Ground
45	GND	SIG	-	-	Ground

- Denotes 5V tolerant I/O
- Standard 3.3V I/O
- Bidirection reset pin with embedded weak pullup

* Note the pin descriptions shown are arbitrary for most MCU connected signals



5.2 Pin Definitions

Of the 44 pads located along 3 edges of the module, 8 connect to GND and 2 are power connections. Most of the remaining module pads are internally connected to the STM32F411 MCU. For this reason, the signal definition of these pins is somewhat arbitrary given that the pin modes can be configured via software.

The signal names provided in the Pin Description table shown in section 4.1 align with the names provided in the Cypress WICED SDK **platform.h** file. Users have the ability to modify these configurations and definitions as explained in the STM32F411 datasheet.



6 Electrical Specifications

For electrical characteristics of the module digital I/O's connected to the internal STM32F411 MCU, refer to the STM32F411 datasheet (Document ID 026289 Rev 4 or later).

6.1 Absolute Maximum Ratings

Parameter	Min	Max	Unit
VDD_3V3_SIP	0	4	Volts
VBAT_SIP	0	4	Volts
Voltage on Digital I/Os	-0.3	4	Volts
Voltage on Analog Inputs	-0.3	4	Volts
Supply Ripple	-2	2	%
Storage Temperature	-40	+85	°C
Operating Temperature	-40	+85	°C

6.2 Recommended Operating Conditions

Parameter	Min	Typ	Max	Unit
VDD_3V3_SIP	3.0	3.3	3.6	Volts
VBAT_SIP	2.0	3.3	3.6	Volts
Voltage on Digital I/Os	0	3.3	VDD_3V3_SIP	Volts
Voltage on Analog Inputs	0	3.3	VDD_3V3_SIP	Volts
Humidity Range*	0		95	%
Operating Temperature	-40	25	+85	°C

* Non-condensing, relative humidity

6.3 Power Supply Requirements

Parameter	Min	Typ	Max	Unit
VDD_3V3_SIP	3.0	3.3	3.6	Volts
VDD_3V3_SIP*	-	-	-	mA
VBAT_SIP	2.0	3.3	3.6	Volts
VBAT_SIP*	-	-	-	mA

* See Power Consumption figures on next page

6.4 WLAN Power Consumption

Condition: 25deg.C, includes both Wi-Fi and Microcontroller

Parameter	Test Condition (+25 °C, 3.3V)	Min	Typ	Max	Unit
11b Tx Mode	11 Mbps	-	400		mA
11g Tx Mode	54 Mbps	-	260		mA
11n Tx Mode	MCS7	-	200		mA
11b Rx Mode	11 Mbps	-	46		mA
11g Rx Mode	54 Mbps	-	46		mA
11n Rx Mode	MCS7	-	46		mA

6.5 Bluetooth Power Consumption

Condition: 25deg.C, includes Both Wi-Fi/BT and Microcontroller

Parameter	Test Condition (+25 °C, 3.3V)	Min	Typ	Max	Unit
Tx Mode	3DH5	-	35		mA
Rx Mode	3DH5	-	16		mA

6.6 Bluetooth Low Energy Power Consumption

Condition: 25deg.C, includes Both Wi-Fi/BT and Microcontroller

Parameter	Test Condition (+25 °C, 3.3V)	Min	Typ	Max	Unit
Tx Mode	Transmitter and baseband @ 100%	-	35		mA
Rx Mode	Receiver and baseband @ 100%	-	16		mA

6.7 Low Power Modes Power Consumption

Parameter	Device	Test Condition (+25 °C, 3.3V)	Min	Typ	Max	Unit
Sleep Mode	STM32F411	-	-	122		uA
	BCM4343W		-	1.48		mA
Power Down Mode	STM32F411	-	-	6.6		mA
	BCM4343W		-	6.0		uA
Idle, Unassociated	STM32F411	-	-	8.6		mA
	BCM4343W		-	366		uA

7 RF Specifications

7.1 WLAN RF Characteristics

The AES-BCM4343W-M1-G module complies with the following WLAN features and standards.

Features	Description
WLAN Standards	IEEE 802 Part 11b/g/n (802.11b/g/n single stream n)
Antenna Port	Supports single antenna for Wi-Fi
Frequency Band	2.400 - 2.484 GHz

The RF performance of the AES-BCM4343W-M1-G module is given as follows (@ 3.3V):

Features	Description
Frequency band	2.4000 - 2.497 GHz (2.4 GHz ISM Band)
Number of selectable sub-channels	14 Channels
Modulation	OFDM, DSSS (Direct Sequence Spread Spectrum), DBPSK, DQPSK, CCK, 16QAM, 64QAM
Supported rates	1, 2, 5.5, 11, 6, 9, 12, 24, 36, 48, 54 Mbps & HT20 MCS 0~7
Maximum receive input level	-10dBm (with PER < 8% @ 11 Mbps) -20dBm (with PER < 10% @ 54 Mbps) -20dBm (with PER < 10% @ MCS7)
Output power	17dBm @ 802.11b 13dBm @ 802.11g 12dBm @ 802.11n
Carrier frequency accuracy	+/- 20 ppm (crystal: 26 MHz +/- 10 ppm @ 25 °C)

7.1.1 Transmitter Specification

7.1.1.1 802.11b Transmitter Specification

Parameter	Test Condition	Min	Typ	Max	Unit
Transmit Output Power Level	1/2/5.5/11 Mbps	-	17	-	dBm
Transmit Center Freq. Tolerance	-	-20	0	20	ppm
Transmit Spectrum Mask	Fc-22MHz<F<Fc-11MHz & Fc+11MHz<F<Fc+22MHz (1/2/5.5/11 Mbps; Channel 1~13)	-	-	-30*	dBr
	F<Fc-22MHz & F>Fc+22MHz (1/2/5.5/11 Mbps; Channel 1~13)	-	-	-50*	dBr
Transmit Power-On	10% ~ 90%	-	0.3	2*	us
Transmit Power-Down	90% ~ 10%	-	1.5	2*	us
Transmit Modulation Accuracy	1/2/5.5/11 Mbps	-	-17	-10	dB

Note 1 - "*" Indicates IEEE802.11 specification

7.1.1.2 802.11g Transmitter Specification

Parameter	Test Condition	Min	Typ	Max	Unit
Transmit Output Power Level	6/9/12/18/24/36/48/54 Mbps	-	13	-	dBm
Transmit Center Freq. Tolerance	-	-20	0	20	ppm
Transmit Modulation Accuracy	6 Mbps	-	-	-5*	dB
	9 Mbps	-	-	-8*	dB
	12 Mbps	-	-	-10*	dB
	18 Mbps	-	-	-13*	dB
	24 Mbps	-	-	-16*	dB
	36 Mbps	-	-	-19*	dB
	48 Mbps	-	-	-22*	dB
	54 Mbps	-	-	-25*	dB
Transmit Spectrum Mask	@ 11 MHz	-	-	-20*	dBr
	@ 20 MHz	-	-	-28*	dBr
	@ 30 MHz	-	-	-40*	dBr

Note 1 - "*" Indicates IEEE802.11 specification

7.1.1.3 802.11n Transmitter Specification

Parameter	Test Condition	Min	Typ	Max	Unit
Transmit Output Power Level	HT20 MCS 0~7	-	12	-	dBm
Transmit Center Freq. Tolerance	-	-20	0	20	ppm
Transmit Modulation Accuracy	HT20, MCS0~7	-	-	-27*	dB
Transmit Spectrum Mask	@ 11 MHz	-	-	-20*	dBr
	@ 20 MHz	-	-	-28*	dBr
	@ 30 MHz	-	-	-40*	dBr

Note 1 - "*" Indicates IEEE802.11 specification

7.1.2 Receiver Specification

7.1.2.1 802.11b Receiver Specification

Parameter	Test Condition	Min	Typ	Max	Unit
Receiver Minimum Input Level Sensitivity (PER < 8%)	1 Mbps	-80*	-93	-	dBm
	2 Mbps	-80*	-91	-	dBm
	5.5 Mbps	-76*	-89	-	dBm
	11 Mbps	-76*	-86	-	dBm
Receiver Maximum Input Level Sensitivity (PER < 8%)	1/2/5.5/11 Mbps	-10*	-	-	dBm

Note 1 - "*" Indicates IEEE802.11 specification

7.1.2.2 802.11g Receiver Specification

Parameter	Test Condition	Min	Typ	Max	Unit
Receiver Min. Input Level Sensitivity (PER < 10%)	6 Mbps	-82*	-88	-	dBm
	9 Mbps	-81*	-87	-	dBm
	12 Mbps	-79*	-85	-	dBm
	18 Mbps	-77*	-83	-	dBm
	24 Mbps	-74*	-80.5	-	dBm
	36 Mbps	-70*	-78.5	-	dBm
	48 Mbps	-66*	-74	-	dBm
	54 Mbps	-65*	-72	-	dBm
Receiver Max. Input Level Sensitivity (PER < 10%)	6/9/12/18/24/36/48/54 Mbps	-20*	-	-	dBm

Note 1 - "*" Indicates IEEE802.11 specification

7.1.2.3 802.11n Receiver Specification

Parameter	Test Condition	Min	Typ	Max	Unit
Receiver Min. Input Level Sensitivity (PER < 10%)	HT20, MSC0	-82*	-87.5	-	dBm
	HT20, MSC1	-79*	-84	-	dBm
	HT20, MSC2	-77*	-82	-	dBm
	HT20, MSC3	-74*	-80.5	-	dBm
	HT20, MSC4	-70*	-77	-	dBm
	HT20, MSC5	-66*	-72	-	dBm
	HT20, MSC6	-65*	-71	-	dBm
	HT20, MSC7	-64*	-70	-	dBm
	MSC0 ~ MSC7	-20*	-	-	dBm
Receiver Max. Input Level Sensitivity (PER < 10%)	MSC0 ~ MSC7	-20*	-	-	dBm

7.2 Bluetooth RF Characteristics

7.2.1 Transmitter Specification

Parameter	Mode and Condition	Min	Typ	Max	Unit
Transmitter Section					
Frequency Range	-	2402.0	-	2480	MHz
Output Power	GFSK	-	10	-	dBm
	QPSK	-	6	-	dBm
	BPSK	-	6	-	dBm
Power Control Step		2	4	8	dB
Lo Performance					
Initial Carrier Freq. Tolerance	-	-	+/-25	+/-75	KHz
Lock Time	-	-	72	-	uS
Frequency Drift					
DH1 Packet	-	-	+/-8	+/-25	KHz
DH3 Packet	-	-	+/-8	+/-40	KHz
DH5 Packet	-	-	+/-8	+/-40	KHz
Drift Rate	-	-	5	20	KHz/50 us
Frequency Deviation					
00001111 Sequence in Payload (a)	-	140	155	175	KHz
10101010 Sequence in Payload (b)	-	115	140	-	KHz
Channel Spacing	-	-	1	-	MHz

(a) This pattern represents an average deviation in payload

(b) Pattern represents the maximum deviation in payload for 99.9% of all frequency deviations

7.2.2 Receiver Specification

Parameter	Mode and Condition	Min	Typ	Max	Unit
Receiver Section					
Frequency Range	-	2402	-	2480	MHz
Output Power	GFSK, 0.1% BER, 1 Mbps	-	-91	-	dBm
	$\pi/4$ -DQPSK, 0.01% BER, 2 Mbps	-	-93	-	dBm
	8-DPSK, 0.01% BER, 3 Mbps	-	-87	-	dBm
Input IP3		-16	-	-	dBm
Maximum Input	-	-	-	-20	dBm

7.3 BLE RF Characteristics

Parameter	Mode and Condition	Min	Typ	Max	Unit
Frequency Range	-	2402	-	2480	MHz
Rx Sense (a)	GFSK, 0.1% BER, 1 Mbps	-	-94	-	dBm
TX Power	-	-	8	-	dBm
Mod Char: Delta f1 Average	-	225	225	275	KHz
Mod Char: Delta f2 max (b)	-	99.9	-	-	%
Mod Char: Ratio	-	0.8	0.95	-	%

Note (a) - The Bluetooth tester is set so that Dirty TX is on

Note (b) - At least 99.9% of all delta F2 max. frequency values recorded over 10 packets must be greater than 185 KHz

8 Mechanical Specifications

8.1 Mechanical Size

Module dimensions are 35 mm x 20 mm x 2.59 mm (max) as shown in the figures below.

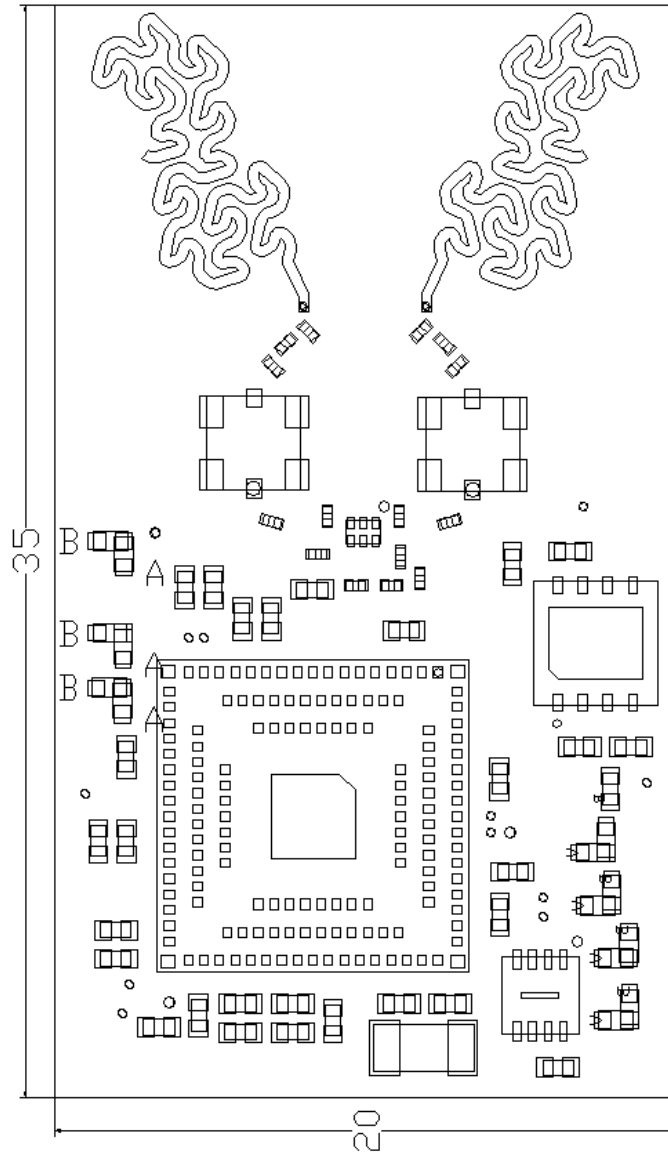

Figure 2 – AES-BCM4343W-M1-G Module Top View

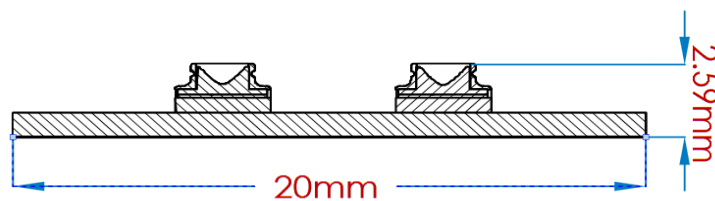

Figure 3 – AES-BCM4343W-M1-G Module Side View

8.2 Module PCB Footprint

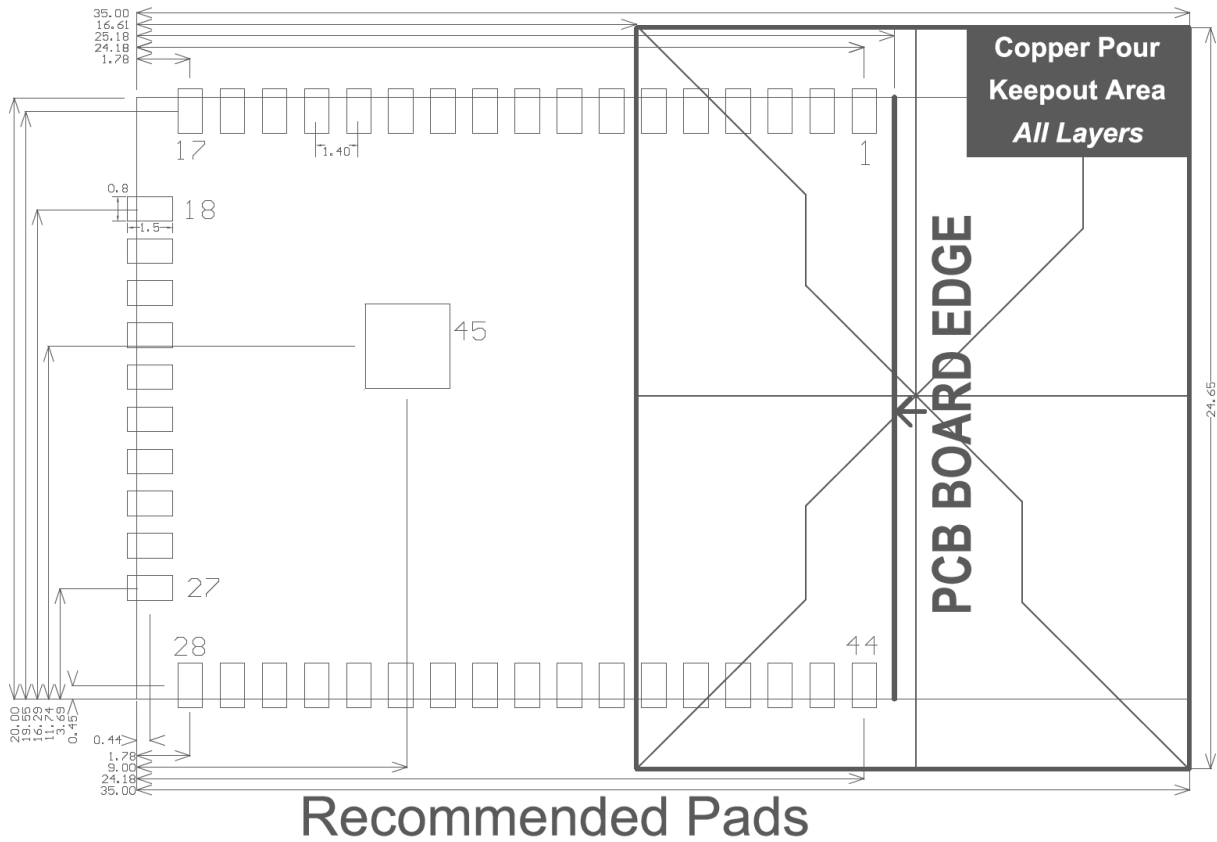

Figure 4 – AES-BCM4343W-M1-G Module PCB Footprint

8.3 Module Pad Size

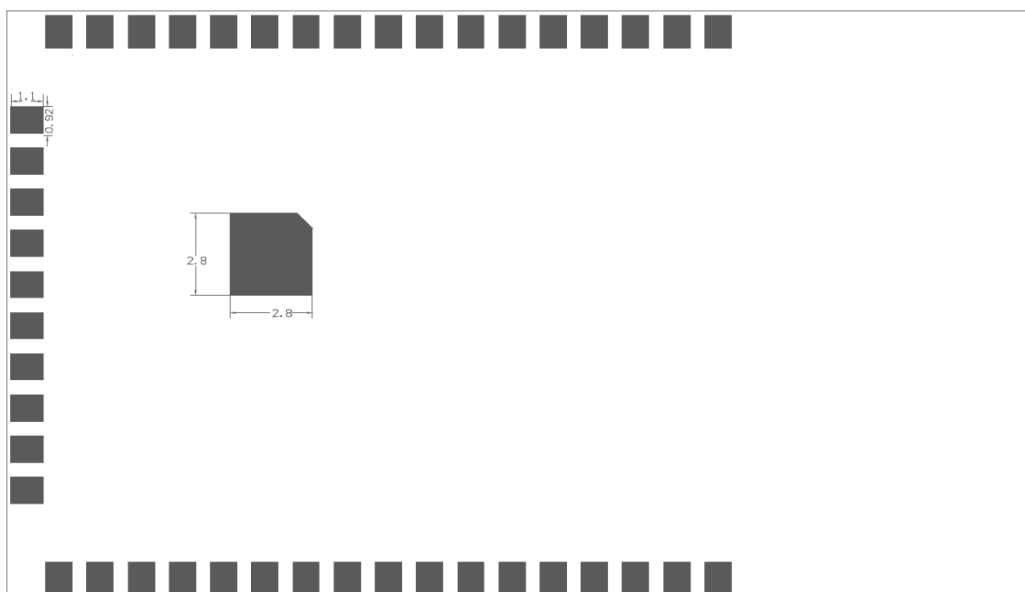

Figure 5 – AES-BCM4343W-M1-G Module Pad Size

8.4 Recommended Solder Paste Mask

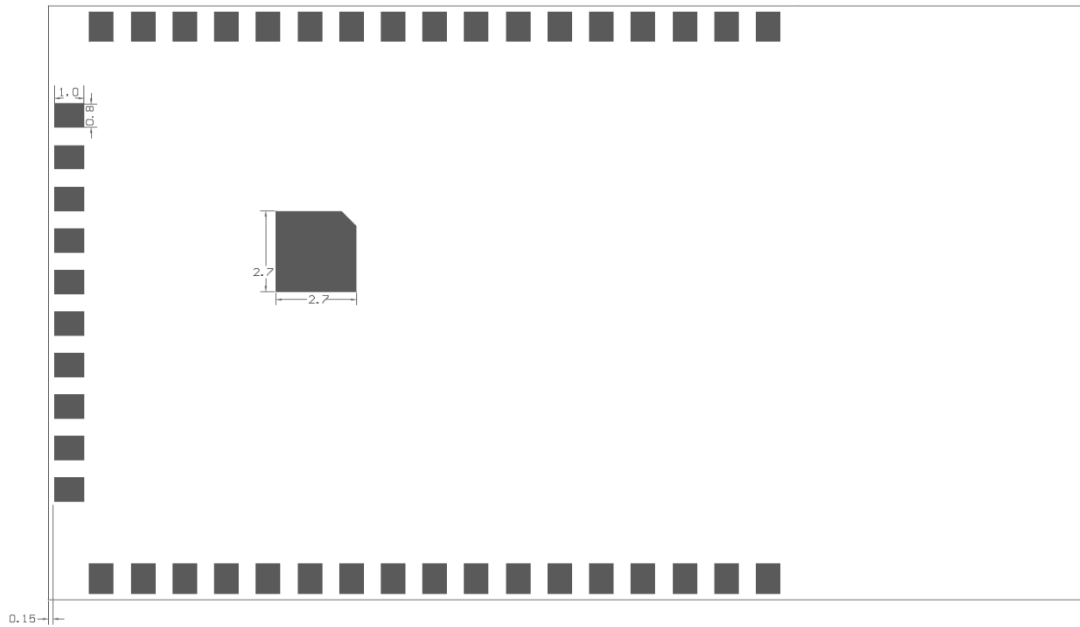

Figure 6 – Recommended Solder Paste Mask Size

8.5 Recommended Solder Mask

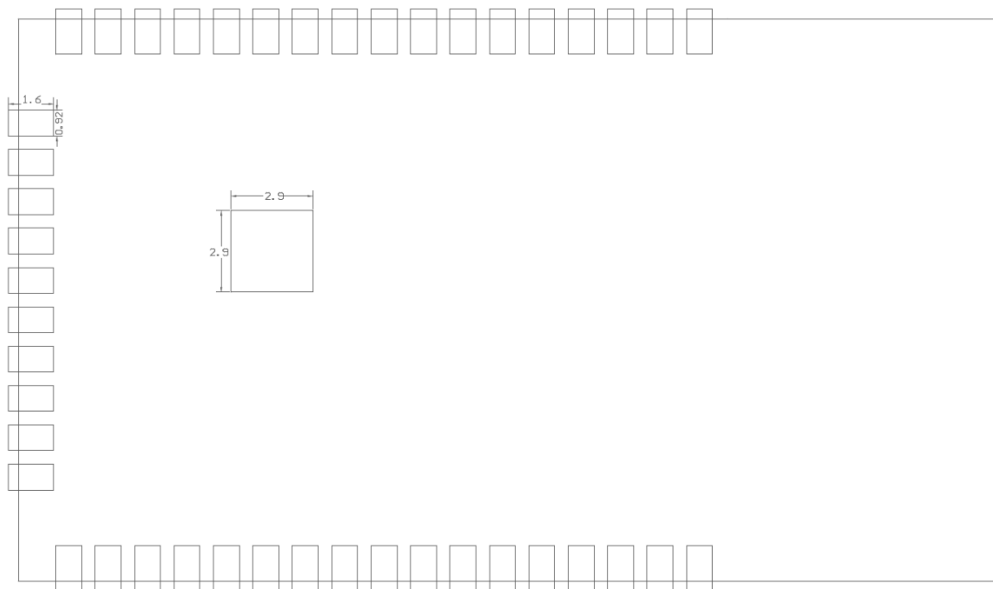

Figure 7 – Recommended Solder Mask Size

8.6 Tape and Reel Packaging

The AES-BCM4343W-M1-G module is available in tape and reel packaging at quantities of 600 units.

The reel dimensions are 13 inches x 56 mm.

The 56 mm tape conforms to the Electronic Components Association Standard EIA-481-D.

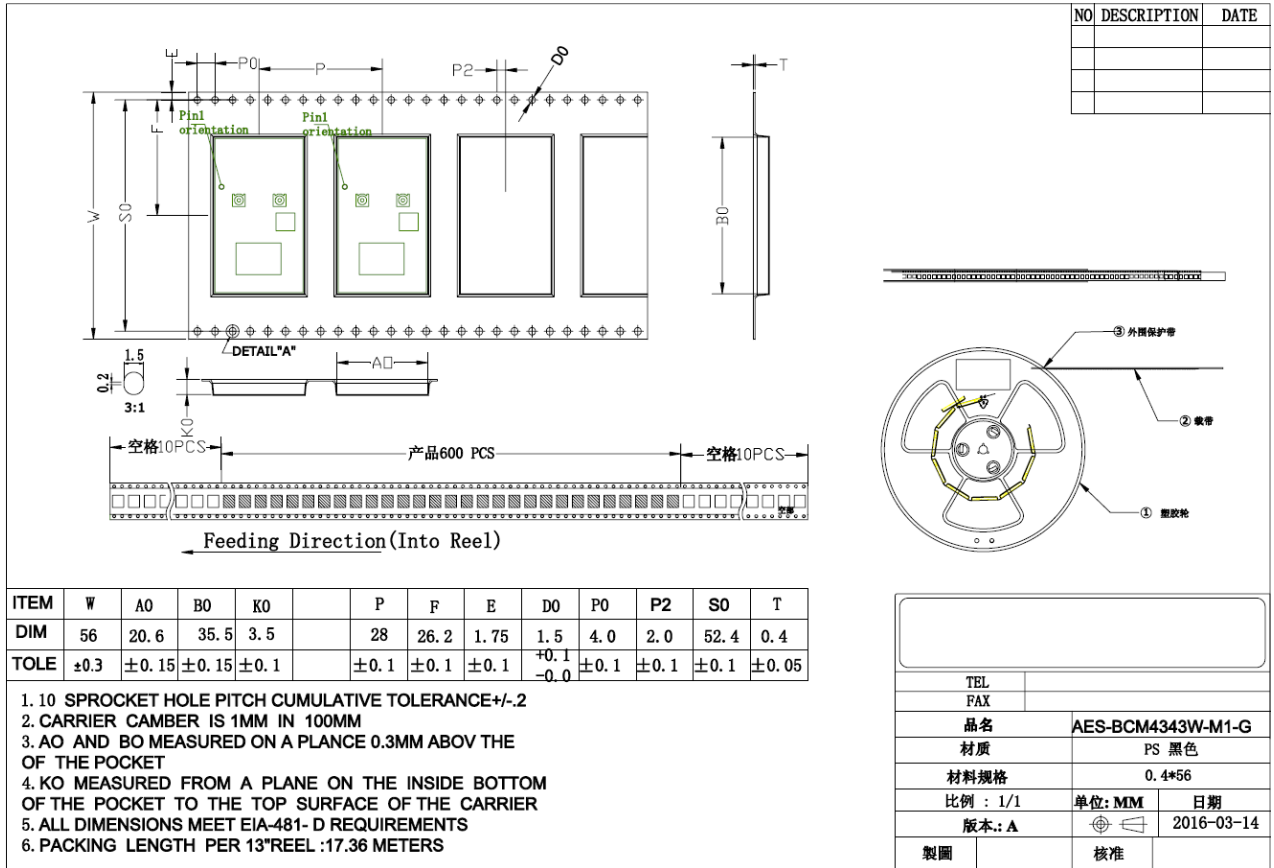

Figure 8 – Tape Dimensions

9 Soldering and Cleaning Recommendations

9.1 Optimum Soldering Reflow Profile

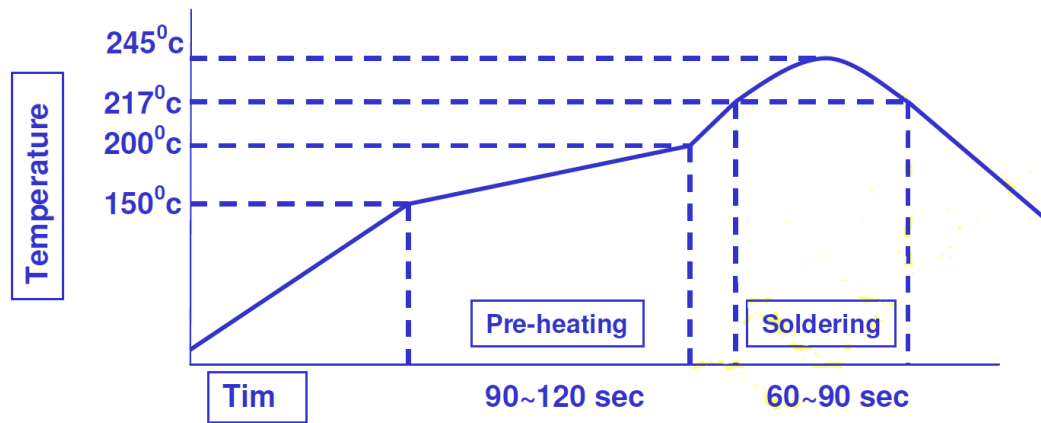

Figure 9 – Recommended Soldering Profile for Lead-Free Solder

Solder joint quality between the module's LGA surface mount pads and their bonding with the host board should meet the appropriate IPC Specification.
(See *IPC-A-610-D Acceptability of Electronic Assemblies*, section 8.2.1 "Bottom Only Terminations")

It is recommended that only a single reflow soldering process be permitted for the host board

Any attempts at reworking the module will invalidate warranty coverage and regulatory certifications

9.2 Cleaning

Cleaning of the populated module is not recommended! Residuals under the module cannot be easily removed by any cleaning process (Water / Solvents / Ultrasonic)

10 Antennas

Two onboard **Fractal PCB antennas** provide antenna diversity and good RF performance. (The Cypress patented PCB antenna trace pattern achieves a gain of 3dBi)

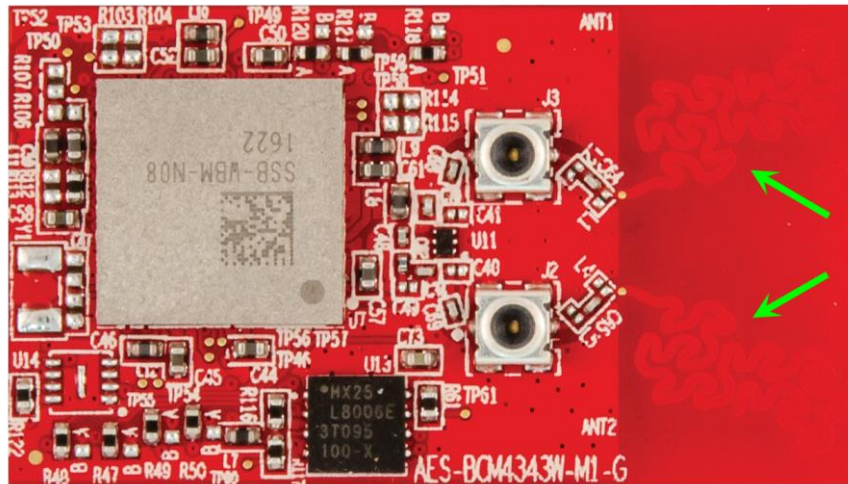

Figure 10 – Dual Fractal PCB Antennas

Two surface mount miniature RF (3mm x 3mm) switched coax connectors are included onboard. **These connectors are for TEST PURPOSES ONLY and shall not be used for external antennas!**

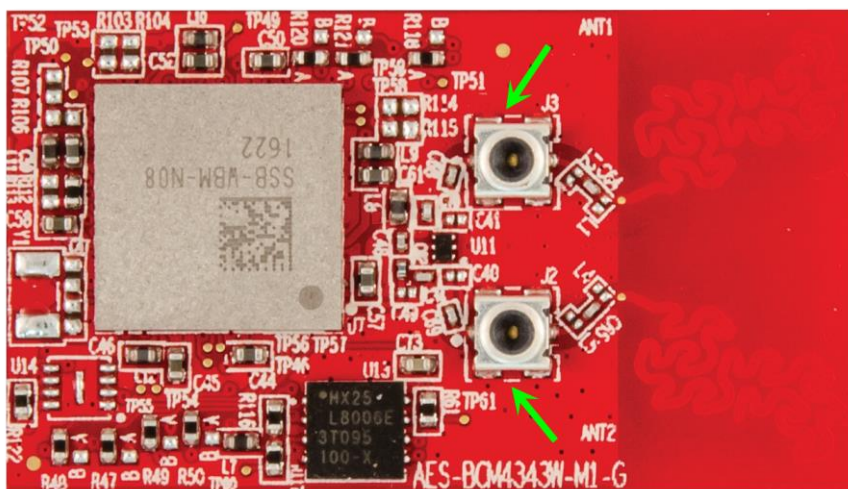

Figure 11 – Test Probe Connectors (Murata SWD series)

Note! Use of external antennas is **not approved** in the regulatory certifications for this module!

11 Certifications

11.1 RoHS

The AES-BCM4343W-M1-G module is lead-free and RoHS compliant.

11.2 Regulatory Compliance

Note: FCC, IC and CE certifications are currently pending

(Once the certification process has been concluded, this note will be removed from the datasheet)

The Avnet AES-BCM4343W-M1-G module certification applies to operation in various regulatory domains. This section outlines certification information specific to the following countries and regions:

- United States
- Canada
- Europe

Regulatory Body	Status
FCC	2AF62-AVTEG001 (Pending)
IC	21571-AVTEG001 (Pending)
CE	EN 60950-1, EN 300 328, EN 301 489 (Pending)
RoHS	Compliant

Should regulatory certification be required in a specific country or region not already covered, please contact your local Avnet sales office or create a support request at <http://cloudconnectkits.org/forum>

11.3 Bluetooth Interoperability Compliance

The BQB application is in progress

11.4 Regulatory Agency Statements

11.4.1 FCC Module Statement (USA)

The single-modular transmitter is a self-contained, physically delineated, component for which compliance can be demonstrated independent of the host operating conditions, and which complies with all eight requirements of § 15.212(a)(1) as summarized below.

- 1) The radio elements have the radio frequency circuitry shielded.
- 2) The module has buffered modulation/data inputs to ensure that the device will comply with Part 15 requirements with any type of input signal.
- 3) The module contains power supply regulation on the module.
- 4) The module contains a permanently attached antenna.
- 5) The module demonstrates compliance in a stand-alone configuration.
- 6) The module is labeled with its permanently affixed FCC ID label
- 7) The module complies with all specific rules applicable to the transmitter, including all the conditions provided in the integration instructions by the grantee.
- 8) The module complies with RF exposure requirements.

11.4.2 FCC Interference Statement (USA)

The user manual for the final end product should include the following statement:

This device complies with Part 15 of the FCC Rules.

Operation is subject to the following two conditions:

- (1) This device may not cause harmful interference, and
- (2) this device must accept any interference received, including interference that may cause undesired operation.

This equipment has been tested and found to comply with the limits for a Class B digital device, pursuant to Part 15 of the FCC Rules. These limits are designed to provide reasonable protection against harmful interference in a residential installation. This equipment generates, uses and can radiate radio frequency energy and, if not installed and used in accordance with the instructions, may cause harmful interference to radio communications. However, there is no guarantee that interference will not occur in a particular installation. If this equipment does cause harmful interference to radio or television reception, which can be determined by turning the equipment off and on, the user is encouraged to try to correct the interference by one of the following measures:

- Reorient or relocate the receiving antenna.
- Increase the separation between the equipment and receiver.
- Connect the equipment into an outlet on a circuit different from that to which the receiver is connected.
- Consult the dealer or an experienced radio/TV technician for help.

11.4.3 FCC RF Exposure Statement (USA)

This equipment complies with FCC RF radiation exposure limits set forth for an uncontrolled environment. This transmitter must not be co-located or operating in conjunction with any other antenna or transmitter

Human exposure to RF emissions from mobile devices (47 CFR §2.1091) may be evaluated based on the MPE limits adopted by the FCC for electric and magnetic field strength and/or power density, as appropriate, since exposures are assumed to occur at distances of 20 cm or more from persons.

The following statement must be included as a CAUTION statement in manuals for the OEM products, to alert users of FCC RF exposure compliance:

“WARNING: To satisfy FCC RF exposure requirements for mobile transmitting devices, a separation distance of 20cm or more should be maintained between the antenna of this device and persons during operation. To ensure compliance, operations at closer distances than this are not recommended”

11.4.4 FCC Cautionary Notices (USA)

IMPORTANT: The AES-BCM4343W-M1-G module has been certified by the FCC for use with other products without any further certification (as per FCC section 2.1091).

Any changes or modifications not expressly approved by the party responsible for compliance, could void the user's authority to operate this equipment.

IMPORTANT: OEMs must test final product to comply with unintentional radiators (FCC section 15.107 & 15.109) before declaring compliance of their final product to Part 15 of the FCC Rules.

11.4.5 FCC Host 15B and 15C Compliance Statement (USA)

A host product itself is required to comply with all other applicable FCC equipment authorization regulations, requirements, and equipment functions that are not associated with the transmitter module portion. For example, compliance must be demonstrated: to regulations for other transmitter components within a host product; to requirements for unintentional radiators (Part 15 Subpart B), such as digital devices, computer peripherals, radio receivers, etc.; and to additional authorization requirements for the non-transmitter functions on the transmitter module (i.e., Verification or Declaration of Conformity) as appropriate (e.g., Bluetooth and Wi-Fi transmitter modules may also contain digital logic functions).

The OEM integrator or host manufacturer is responsible for the overall compliance of the host products

11.4.6 IC Statement (Canada)

The Avnet AES-BCM4343W-M1-G module has been certified for use in Canada under Industry Canada (IC) Radio Standards Specification (RSS) RSS-210 and RSSGen.

Modular approval permits the installation of a module in a host device without the need to recertify the device.

11.4.7 IC Labeling Requirements (Canada)

The user manual for the final end product shall display the following Industry Canada notices in a conspicuous location:

Industry Canada Statements

This Device complies with Industry Canada License-exempt RSS standard(s). Operation is subject to the following two conditions: (1) this device may not cause interference, and (2) this device must accept any interference, including interference that may cause undesired operation of the device.

Le présent appareil est conforme aux CNR d'Industrie Canada applicables aux appareils radio exempts de licence. L'exploitation est autorisée aux deux conditions suivantes: (1) l'appareil ne doit pas produire de brouillage, et (2) l'utilisateur de l'appareil doit accepter tout brouillage radioélectrique subi, même si le brouillage est susceptible d'en compromettre le fonctionnement.

Under Industry Canada regulations, this radio transmitter may only operate using an antenna of a type and maximum (or lesser) gain approved for the transmitter by Industry Canada. To reduce potential radio interference to other users, the antenna type and its gain should be so chosen that the equivalent isotropically radiated power (EIRP) is not more than that necessary for successful communication.

Conformément à la réglementation d'Industrie Canada, le présent émetteur radio peut fonctionner avec une antenne d'un type et d'un gain maximal (ou inférieur) approuvé pour l'émetteur par Industrie Canada. Dans le but de réduire les risques de brouillage radioélectrique à l'intention des autres utilisateurs, il faut choisir le type d'antenne et son gain de sorte que la puissance isotrope rayonnée équivalente (p.i.r.e.) ne dépasse pas l'intensité nécessaire à l'établissement d'une communication satisfaisante.

11.4.8 CE Statement (Europe)

The Avnet AES-BCM4343W-M1-G module has been tested and certified for use in the European Union.

Summary of European Compliance Tests:

Certification	Standard	Report Number	Laboratory
Safety	EN 60950-1:2006, A11:2009, A1:2010, A12:2011, A2:2013	AGC07088160601ES01	AGC Shenzhen
EMF	EN 62311:2008 EN 62479:2010	AGC07088160601EH04 AGC07088160601EH02	AGC Shenzhen
EMC	EN 301 489-1 V1.9.2 EN 301 489-17 V2.2.1	AGC07088160601EE01	AGC Shenzhen
Radio	EN 300 328 V1.9.1	AGC07088160601EE05 AGC07088160601EE06	AGC Shenzhen

When integrating this module into an end product, the OEM has responsibility to verify compliance of the final product to the EU standards.

A Declaration of Conformity (DOC) must be issued and kept on file as described in Annex II of the Radio and Telecommunications Terminal Equipment (R&TTE) Directive.

11.4.9 CE Labeling Requirements (Europe)

The 'CE' mark must be placed on the OEM product per the labeling requirements of the R&TTE Directive.

11.5 OEM Instructions

This module has been certified for installation into products only by OEM integrators under the following conditions:

The antennas used with this module must be installed to provide a separation distance of at least 20cm from all persons, and must not be co-located or transmit simultaneously with any other antenna or transmitter, except in accordance with FCC multi transmitter product procedures.

11.6 OEM Labeling Requirements

A clearly visible label is required, affixed to the outside of the user's (OEM) enclosure. This label should display the following:

Contains FCC ID: 2AF62-AVTEG001
Contains IC: 21571-AVTEG001
 This device complies with Part 15 of the FCC Rules.
 Operation is subject to the following two conditions:
 (1) This device may not cause harmful interference, and
 (2) This device must accept any interference received,
 including interference that may cause undesired operation.

11.7 Limitations

This product is not intended for use in safety-critical applications (such as life support or automotive) where a failure of the Avnet product could be expected to cause severe personal injury or death. Please refer to the final section of this document for additional restrictions to Avnet's legal liability

12 Shipping, Handling and Storage

12.1 Shipping

Bulk orders of the Avnet BCM4343W SoC module are delivered in reels of 600.
(See Section 7.6 for detail)

12.2 Handling

The AES-BCM4343W-M1-G module contains sensitive electronic circuitry that require proper ESD protection when handling. Failure to follow these ESD procedures may result in permanent damage to the module.

The module should not be subjected to excessive mechanical shock.

12.3 Moisture Sensitivity (MSL)

Modules that have been exposed to moisture and environmental conditions exceeding the prescribed packaging and storage conditions detailed in J-STD-020 (eg. not continuously in a sealed bag with a desiccant pack) **MUST** be baked before mounting! (Failure to meet the packaging and storage conditions described, will result in irreparable damage to modules during solder reflow soldering).

For devices that are packaged in a Moisture Barrier Bag with a desiccant pack and HIC (Humidity Indicator Card), the HIC card should be referenced and J-STD-033 consulted to determine if baking is required prior to reflow soldering.

In cases where baking is required, refer to J-STD-033 for details of the bake procedure.

“Broken reel” module quantities (under 600 units) typically require baking before reflow soldering

12.4 Storage

Per J-STD-033, the shelf life of devices in a Moisture Barrier Bag is 12 months at <40°C and <90% room humidity (RH).

Do not store in salty air or an environment where there is a high concentration of corrosive gas, such as Cl₂, H₂S, NH₃, SO₂, or NO_x.

Do not store in direct sunlight.

13 Ordering Information

Part Number	Description
AES-BCM4343W-M1-G	802.11 b/g/n WLAN, Bluetooth & BLE SoC Module

13.1 Module Accessories

Manuf.	Part Number	Description
Avnet	AES-EVB-BCM4343W-G	BCM4343W IoT Starter Kit

14 Contact Information

For further details, contact your local Avnet representative or e-mail us at:

Region	Organization	Email
North America	Avnet EMA	eval.kits@avnet.com
Europe	Avnet EBV	ebvchips@ebv.com
	Avnet Silica	info@avnet.eu
Asia	Avnet Asia	XilinxAPAC@avnet.com

Avnet Module License and Product Warranty

THIS AVNET MODULE (OR “PRODUCT”) AND ANY SUPPORTING DOCUMENTATION IS SUBJECT TO THIS LICENSE AGREEMENT. USE OF THIS PRODUCT OR DOCUMENTATION SIGNIFIES ACCEPTANCE OF THE TERMS AND CONDITIONS OF THIS LICENSE. THE TERMS OF THIS LICENSE AGREEMENT ARE IN ADDITION TO THE AVNET CUSTOMER TERMS AND CONDITIONS, WHICH CAN BE VIEWED AT www.em.avnet.com THE TERMS OF THIS LICENSE AGREEMENT WILL CONTROL IN THE EVENT OF A CONFLICT

1. Limited License. Avnet grants You, the Customer, (“You” “Your” or “Customer”) a limited, non-exclusive, non-transferable, license to: (a) use the Product for Your own internal testing, evaluation and design efforts at a single Customer site; (c) make, use and sell the Product in a single production unit. No other rights are granted and Avnet and any other Product licensor reserves all rights not specifically granted in this License Agreement. Except as expressly permitted in this License, neither the Module, Documentation, nor any portion may be reverse engineered, disassembled, decompiled, sold, donated, shared, leased, assigned, sublicensed or otherwise transferred by Customer. The term of this License is in effect until terminated. Customer may terminate this license at any time by destroying the Product and all copies of the Product Documentation.

2. Changes. Avnet may make changes to the Product or Product Documentation at any time without notice. Avnet makes no commitment to update or upgrade the Product or Product Documentation and Avnet reserves the right to discontinue the Product or Product Documentation at any time without notice.

3. Product Documentation. Product Documentation is provided by Avnet on an “AS-IS” basis and does not form a part of the properties of the Product. All Product Documentation is subject to change without notice. Avnet makes no representation as to the accuracy or completeness of the Product Documentation, and DISCLAIMS ALL REPRESENTATIONS, WARRANTIES AND LIABILITIES UNDER ANY THEORY WITH RESPECT TO PRODUCT INFORMATION.

4. Limited Product Warranty. AVNET WARRANTS THAT AT THE TIME OF DELIVERY, THE PRODUCTS SHALL MEET THE SPECIFICATIONS STATED IN AVNET DOCUMENTATION FOR SIXTY (60) DAYS FROM DELIVERY OF PRODUCTS. IF THE CUSTOMER CAN PROVIDE PROOF THAT THE QUALIFIED AVNET PRODUCT WAS PURCHASED FOR THE PURPOSE OF AND DEPLOYED AS A COMPONENT IN THE CUSTOMER’S COMMERCIALY AVAILABLE PRODUCT THE WARRANTY WILL BE EXTENDED TO TWELVE (12) MONTHS FROM THE DATE OF PURCHASE. TO THE EXTENT PERMITTED BY LAW, AVNET MAKES NO OTHER WARRANTY, EXPRESS OR IMPLIED, SUCH AS WARRANTY OF MERCHANTABILITY, FITNESS FOR PURPOSE OR NON-INFRINGEMENT. YOUR SOLE AND EXCLUSIVE REMEDY FOR BREACH OF AVNET’S WARRANTY IS, AT AVNET’S CHOICE: (i) REPAIR THE PRODUCTS; (ii) REPLACE THE PRODUCTS AT NO COST TO YOU; OR (iii) REFUND YOU THE PURCHASE PRICE OF PRODUCTS.

5. LIMITATIONS OF LIABILITY. CUSTOMER SHALL NOT BE ENTITLED TO AND AVNET WILL NOT BE LIABLE FOR ANY INDIRECT, SPECIAL, INCIDENTAL OR CONSEQUENTIAL DAMAGES OF ANY KIND OR NATURE, INCLUDING, WITHOUT LIMITATION, BUSINESS INTERRUPTION COSTS, LOSS OF PROFIT OR REVENUE, LOSS OF DATA, PROMOTIONAL OR MANUFACTURING EXPENSES, OVERHEAD, COSTS OR EXPENSES ASSOCIATED WITH WARRANTY OR INTELLECTUAL PROPERTY INFRINGEMENT CLAIMS, INJURY TO REPUTATION OR LOSS OF CUSTOMERS, EVEN IF AVNET HAS BEEN ADVISED OF THE POSSIBILITY OF SUCH DAMAGES. THE PRODUCTS AND DOCUMENTATION ARE NOT DESIGNED, AUTHORIZED OR WARRANTED TO BE SUITABLE FOR USE IN MEDICAL, MILITARY, AIR CRAFT, SPACE OR LIFE SUPPORT EQUIPMENT NOR IN APPLICATIONS WHERE FAILURE OR MALFUNCTION OF THE PRODUCTS CAN REASONABLY BE EXPECTED TO RESULT IN A PERSONAL INJURY, DEATH OR SEVERE PROPERTY OR ENVIRONMENTAL DAMAGE. INCLUSION OR USE OF PRODUCTS IN SUCH EQUIPMENT OR APPLICATIONS, WITHOUT PRIOR AUTHORIZATION IN WRITING OF AVNET, IS NOT PERMITTED AND IS AT CUSTOMER’S OWN RISK. CUSTOMER AGREES TO FULLY INDEMNIFY AVNET FOR

ANY DAMAGES RESULTING FROM SUCH INCLUSION OR USE.

6. LIMITATION OF DAMAGES. CUSTOMER'S RECOVERY FROM AVNET FOR ANY CLAIM SHALL NOT EXCEED CUSTOMER'S PURCHASE PRICE FOR THE PRODUCT GIVING RISE TO SUCH CLAIM IRRESPECTIVE OF THE NATURE OF THE CLAIM, WHETHER IN CONTRACT, TORT, WARRANTY, OR OTHERWISE.

7. INDEMNIFICATION. AVNET SHALL NOT BE LIABLE FOR AND CUSTOMER SHALL INDEMNIFY, DEFEND AND HOLD AVNET HARMLESS FROM ANY CLAIMS BASED ON AVNET'S COMPLIANCE WITH CUSTOMER'S DESIGNS, SPECIFICATIONS OR INSTRUCTIONS, OR MODIFICATION OF ANY PRODUCT BY PARTIES OTHER THAN AVNET, OR USE IN COMBINATION WITH OTHER PRODUCTS.

8. U.S. Government Restricted Rights. The Product and Product Documentation are provided with "RESTRICTED RIGHTS." If the Product and Product Documentation and related technology or documentation are provided to or made available to the United States Government, any use, duplication, or disclosure by the United States Government is subject to restrictions applicable to proprietary commercial computer software as set forth in FAR 52.227-14 and DFAR 252.227-7013, et seq., its successor and other applicable laws and regulations. Use of the Product by the United States Government constitutes acknowledgment of the proprietary rights of Avnet and any third parties. No other governments are authorized to use the Product without written agreement of Avnet and applicable third parties.

9. Ownership. Licensee acknowledges and agrees that Avnet or Avnet's licensors are the sole and exclusive owner of all Intellectual Property Rights in the Licensed Materials, and Licensee shall acquire no right, title, or interest in the Licensed Materials, other than any rights expressly granted in this Agreement.

10. Intellectual Property. All trademarks, service marks, logos, slogans, domain names and trade names (collectively "Marks") are the properties of their respective owners. Avnet disclaims any proprietary interest in Marks other than its own. Avnet and AV design logos are registered trademarks and service marks of Avnet, Inc. Avnet's Marks may be used only with the prior written permission of Avnet, Inc.

11. General. The terms and conditions set forth in the License Agreement or at www.em.avnet.com will apply notwithstanding any conflicting, contrary or additional terms and conditions in any purchase order, sales acknowledgement confirmation or other document. If there is any conflict, the terms of this License Agreement will control. This License may not be assigned by Customer, by operation of law, merger or otherwise, without the prior written consent of Avnet and any attempted or purported assignment shall be void. Licensee understands that portions of the Licensed Materials may have been licensed to Avnet from third parties and that such third parties are intended beneficiaries of the provisions of this Agreement. In the event any of the provisions of this Agreement are for any reason determined to be void or unenforceable, the remaining provisions will remain in full effect. This constitutes the entire agreement between the parties with respect to the use of this Product, and supersedes all prior or contemporaneous understandings or agreements, written or oral, regarding such subject matter. No waiver or modification is effective unless agreed to in writing and signed by authorized representatives of both parties. The obligations, rights, terms and conditions shall be binding on the parties and their respective successors and assigns. The License Agreement is governed by and construed in accordance with the laws of the State of Arizona excluding any law or principle, which would apply the law of any other jurisdiction. The United Nations Convention for the International Sale of Goods shall not apply.

Copyright © 2016, Avnet, Inc. All rights reserved. Published by Avnet Electronics Marketing, a group of Avnet, Inc. Avnet, Inc. disclaims any proprietary interest or right in any trademarks, service marks, logos, domain names, company names, brands, product names, or other form of intellectual property other than its own. AVNET and the AV logos are registered trademarks of Avnet, Inc.